

Description

® photoelectric and photoelectric-heat detectors provide many of the proven analog sensing features for applications where detectors are connected to conventional two wire or four wire initiating device circuits (IDCs). Each detector has an onboard microprocessor that evaluates its photoelectric light scattering chamber activity. The onboard microprocessor makes an intelligent decision based on light scattering history as to whether an alarm condition is present.

photoelectric-heat detectors combine photoelectric smoke detection technology and quick response, thermistor-based heat detection technology into a sophisticated, intelligent detector. The detector analyzes each of these activities and their combination to determine whether alarm conditions are present. As a result, this microprocessor based analog detection maintains response to conditions indicative of faster acting, hot flaming fires when compared to the response of either photoelectric smoke activity or thermal activity alone, while maintaining the established high level of immunity to false alarms and nuisance alarms that is inherent with the sensor operation.

False alarm resistant detection. An onboard microprocessor provides photoelectric detection with sensitivity drift compensation, using either photoelectric or photoelectric/heat trending analysis for alarm detection. If any of these alarm conditions are experienced, an alarm is initiated.

heat detectors use a fast response, thermistor based design to provide temperature sensing that quickly, accurately, and consistently identifies when fixed temperatures are exceeded. The fixed temperature sensing thermistor tracks the local ambient temperature. This eliminates the time required to melt a lead pellet or heat a bimetallic element as occurs in mechanical heat detector designs and provides the required heat detection for most applications.

Rate-of-rise (RoR) detection is determined by the comparison of two thermistor responses. By the combination of accurate thermistors with proper physical placement, this rate-of-rise detection design achieves a superior performance that is not normally available with mechanical detection. Rate-of-rise heat detection occurs at $\geq 20^{\circ} \text{ F/min}$ (11° C/min). To minimize the possibility of false alarms, rate-of-rise detection is correlated to the ambient temperature and only activates at more than 90° F (32° C).

The detectors are packaged in a registered design housing that minimizes the visibility of the air intake louvers from the normal viewing locations and maintains a high performance smoke capture ability. Bases are available for remote alarm LED indicator connections and auxiliary relay outputs.

Figure 1: Heat detector



Callout	Description
A	Status indicator, red LED
B	Unlock aperture with a clip on the base to secure the detector into the base.

Features

Note: * UL and ULC approvals are specific to particular photo and photo-heat detectors SKUs. For details see [Table 2](#).

Figure 2: A4098-5602 Photo-Heat or A4098-5601 Photo detector



Photoelectric detection and photoelectric with heat detection:

- Stable and reliable photoelectric smoke detection with built-in sensitivity drift compensation.
- Correlation of smoke activity and thermal activity that provides intelligent fire detection that is more resilient than with either activity alone.

Heat detection:

- Includes both rate-of-rise and fixed temperature thermistor-based detection.
- Detects abnormally high rates of rising temperatures and abnormally high temperatures respectively.

Functional chamber enclosure:

- Concentric baffle design enhances smoke capture by the direction of flow to the chamber.
- Entrance areas are minimally visible when ceiling mounted.
- Operation is for ceiling or wall mounting

Multi-function LED indicator:

- Indicates normal and alarm conditions
- Provides status during a magnetic functional test

Magnetically operated functional test:

- Initiates an alarm and verifies performance
- Identifies general sensitivity status with detector LED pulses
- With detectors categorized as normal or needing cleaning or other service, maintenance priorities can be more easily determined

Available options:

- Bases for two wire or four wire operation
- Auxiliary alarm relay output
- Remote alarm LED indicator

Designed for EMI compatibility

Photo and Photo-Heat detectors are listed to UL standard 268 Edition 7. Heat detectors are listed to UL standard 521 Edition 7.

Specifications

Table 1: Specifications

Specifications	Detector data			
Detector PID	A4098-5602, A4098-5604 ¹	A4098-5601, A4098-5603 ¹	A4098-5611, A4098-5612 ²	A4098-5610, A4098-5613 ³
Type of detector	Photo-Heat	Photo	Heat	Heat RoR
Operating voltage, two wire	10.5 to 33 VDC	10.5 to 33 VDC	10.5 to 33 VDC	10.5 to 33 VDC
Rated voltage, four wire	15 to 32 VDC	15 to 32 VDC	15 to 32 VDC	15 to 32 VDC
Input ripple voltage	25% max.	25% max.	25% max.	25% max.
Max. alarm current	64 mA at 30 V, 33 mA at 20 V, 14.5 mA at 12 V			
Surge current	<200 µA	<200 µA	<200 µA	<200 µA
Standby current	<70 µA	<70 µA	<70 µA	<70 µA
Heat element rating	135°F (57.2°C)	n/a	135°F (57.2°C)	135°F (57.2°C) fixed temperature and rate-of-rise.
Rate-of-rise temperature alarm	n/a	n/a	n/a	>=20°F/min (11°C/min), only in effect at temperature >90°F (32°C)
Humidity range, non-condensing	10-95% RH	10-95% RH	10-95% RH	10-95% RH
Air velocity range	0-2000 FPM	0-2000 FPM	n/a	n/a
Ambient operating temperature range ⁴	32°F to 100.4°F (0°C to 38°C)	32°F to 100.4°F (0°C to 38°C)	32°F to 122°F (0°C to 50°C)	32°F to 122°F (0°C to 50°C)
Storage temperature	-22°F to 158°F (30°C to 70°C)			

Table 1: Specifications

Specifications	Detector data
Height	42mm (1 5/8 in.) 53mm (2 1/8 in.) with base
Material	All plastic parts: flame retardant ABS or PC-ABS
Mounting position	Mount on or close to ceiling, out of direct sunlight
Environment	Only indoor application

Note:

1. A4098-5603 and A4098-5604 detectors are ULC listed.
2. The heating element for A4098-5612 is rated at 200°F or 93.3°C .
3. The heating element for A4098-5613 is rated at 200°F or 93.3°C fixed temperature and rate-of-rise.
4. Ambient operating temperatures only refer to normal installation temperatures. During fire conditions, the detectors experience considerably higher temperatures, but they can continue to function at the higher alarm temperatures.

Smoke detector features

Intelligent data evaluation. Conventional smoke detectors typically become too sensitive due to the accumulation of dust and dirt. With microprocessor based analog detection, data from the photoelectric chamber is monitored and analyzed at the detector to provide a continuously shifting reference point.

Drift compensation. The data evaluation and its shifting reference point provide a software filtering process that compensates for environmental factors such as dust or dirt, and component aging. This establishes an accurate reference for evaluating new activity. With this filtering, the resulting drift compensation significantly reduces the probability of false or nuisance alarms caused by shifts in sensitivity – either up or down.

Maintained sensitivity and dirty status indications.

With its onboard software compensation, the A4098-5601 and A4098-5602 maintain their sensitivity much longer in the presence of dust and dirt accumulation. Additionally, it determines when the dirt accumulation is near the limit of compensation, and indicates that condition through its status indicator LED. See diagnostic information.

Magnetic test information

The detectors have self-monitoring feature that enables them to detect problems. To check the status information, perform the magnetic test and observe the detector LED pulses. The LED normally goes directly into alarm with the magnetic test. If there is an off-normal condition, the LED pulses first to indicate the condition and then goes into alarm. See [Detector status LED indications](#) and [Table 8](#) Magnetic test LED response.

Note: Replace the photo detector when it is dirty. Contact your local branch office.

Application reference

Observe heat detector location guidelines. Ambient temperature operating range is 32°F to 100°F (0°C to 38°C). Temperature fluctuations must be less than 6°F/min (3.3°C/min).

Detector locations. Determine locations only after careful consideration of the physical layout and contents of the area to be protected. Refer to NFPA 72, *the National Fire Alarm Code*. On smooth ceilings, smoke detector spacing of 30 ft (9.1 m) may be used as a guide. For detailed installation information, refer to *A4098 Detectors, Sensors, and Bases Application Manual (574-709AC)*.

Product Selection

Table 2: Detector types

PID	Description	Compatibility
A4098-5602	Photo-Heat detector listed to UL.	Compatible with bases: A4098-5207, A4098-5261, A4098-5680, and A4098-5682
A4098-5604	Photo-Heat detector listed to ULC.	
A4098-5601	Photo detector listed to UL.	
A4098-5603	Photo detector listed to ULC.	
A4098-5610	Heat detector at a 135°F or 57.2°C fixed temperature and rate-of-rise.	
A4098-5611	Heat detector at a 135°F or 57.2°C fixed temperature .	
A4098-5612	Heat detector at a 200°F or 93.3°C fixed temperature.	
A4098-5613	Heat detector at a 200°F or 93.3°C fixed temperature and rate-of-rise.	

Note: The heat detectors are listed to both UL and ULC standards.

Table 3: Maximum spacing between heat detectors

Model	Rating	Type	UL Maximum Spacing
A4098-5610	135°F or 57.2°C	Fixed with rate-of rise	50 ft
A4098-5611		Fixed temperature	50 ft
A4098-5612	200°F or 93.3°C	Fixed temperature	50 ft
A4098-5613		Fixed with rate-of rise	50 ft

Table 4: Compatible bases





SKU	Description	Details*
A4098-5207	Two wire 5 in. base for conventional/ addressable detectors with connections for remote alarm LED indicator	IDC and LED connections are screw terminals for in/out wiring, 18 to 14 AWG
A4098-5261	Two wire 4 in. base for conventional/ addressable detectors with connections for remote alarm LED indicator	IDC and LED connections are screw terminals for in/out wiring, 18 to 14 AWG
A4098-5682	Four wire 5 in. base with Auxiliary Alarm Relay Contacts and connections for Remote LED Alarm Indicator Note: Requires external 24 VDC for operation	Relay ratings, single form "C", for suppressed loads: Power limited, 3 A at 28 VDC. Non-power limited, 3 A at 120 VAC
		Wiring connections (In/Out where required): Relay contacts and IDC wiring, color coded 18 AWG leads. LED wiring, screw terminals for 18 AWG to 14 AWG
A4098-5680	Two wire 5 in. base with Auxiliary Alarm Relay and connections for Remote LED Indicator Note: Connect as the only device on the IDC to ensure relay operation.	Relay ratings, dual form "C", for suppressed loads: Power limited, 1 A at 28 VDC. Non-power limited, 1/2 A at 120 VAC
		Wiring connections (In/Out where required): Relay contacts and IDC (-), color coded 18 AWG leads. IDC (+) and LED wiring, screw terminals for 18 to 14 AWG

Note:

Table 5: Detector accessories

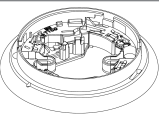
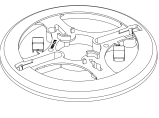
SKU	Description	Details*
4098-9799	6 in. adapter plate used with a 5 in. base	Required to mount to surface mounted 4 in. (102 mm) square or 4 in. octagonal boxes, and to 4 in. square flush mounted boxes
		You can use it when to retrofit to existing bases
		Compatible with detector base A4098-5207
A4098-9830	Remote LED indicator	Mounted on single gang stainless steel plate
A2098-9739	Encapsulated	24 VDC End-of-Line Relay Dimensions: 2-1/2 in. x 1-1/2 in x 1 in. (64 mm x 38 mm x 25.4 mm)
A2098-9735	Plate Mounted	
		Mounted on single gang stainless steel plate
		Required for four wire circuits using A4098-5682 base, one for each circuit. Select mounting type as required. Wiring is color coded 18 AWG wire leads
* Refer to Dimensions and reference information for dimensions and additional mounting details. 18 AWG = 0.82 mm ² . 14 AWG = 2.08 mm ²		

Table 6: Base/Adaptor and Backbox compatibility

Base / Adapter	Single gang / Handy box Approximately 4 in. x 2 in. (102 mm x 51 mm) 83 mm fixing centers	3.5 in. Octagon Diameter 3.5 in. (89 mm) 70 mm fixing centers	4 in. Octagon Diameter 4 in. (102 mm) 90 mm fixing centers	4 in. Square 4 in. x 4 in. (102 mm x 102 mm) 120 mm fixing centers
 4 in. Base A4098-5261 Outside diameter 4.3 in. (109 mm). Fixing centers 50 mm to 70 mm.	No	Yes	No	No
 5 in. Base A4098-5207 Outside diameter 4.9 in. (125 mm). Fixing centers 50 mm to 88 mm. See note.	Yes	Yes	Yes See note.	No
 5 in. Base A4098-5207 with new 5 in. to 6 in. adapter. Outside diameter 6.3 in. (160 mm). 4098-9799 Fixing centers 50 mm to 130 mm.	Yes	Yes	Yes	Yes
 A4098-5210 (Eaton) Sounder Base Outside diameter 4.3 in. (109 mm). Fixing centers 50 mm to 70 mm.	No	Yes	No	No
 A4098-5210 with new 5 in. adapter plate A4098-5227. Fixing centers 50 mm to 90 mm.	Yes	Yes	Yes	No
 A4098-5210 with new 6 in. adapter plate A4098-5228. Fixing centers 50 mm to 130 mm.	Yes	Yes	Yes	Yes

Note: Increased to 90 mm on the latest design for A4098-5207

Detector status LED indications

Table 7: Detector status LED indications

LED indication	Status
Pulses approximately every 4 seconds	Normal
Steady on	Alarm

Table 8: Magnetic test LED response

Fault Type	LED	Fault Description
Fault A	Red LED flashes four times every two seconds then the detector goes into alarm	Detector is within 10% of drift compensation limit
Fault B	Red LED flashes six times every one second then the detector goes into alarm	Heat sensing element is damaged in the Optical Heat detector
Fault C	Red LED flashes four times every two seconds but the detector does not go into alarm. The LED continues to flash while the magnet is in place and 10 seconds afterwards. The detector then returns to normal operation. The detector becomes more sensitive and risks false alarm.	Detector has reached drift compensation limit or the optical sensor or the heat sensor is faulty.

Dimensions and reference information

Figure 3: A4098-5601 and A4098-5602 dimensions mounted on base, in. (mm)

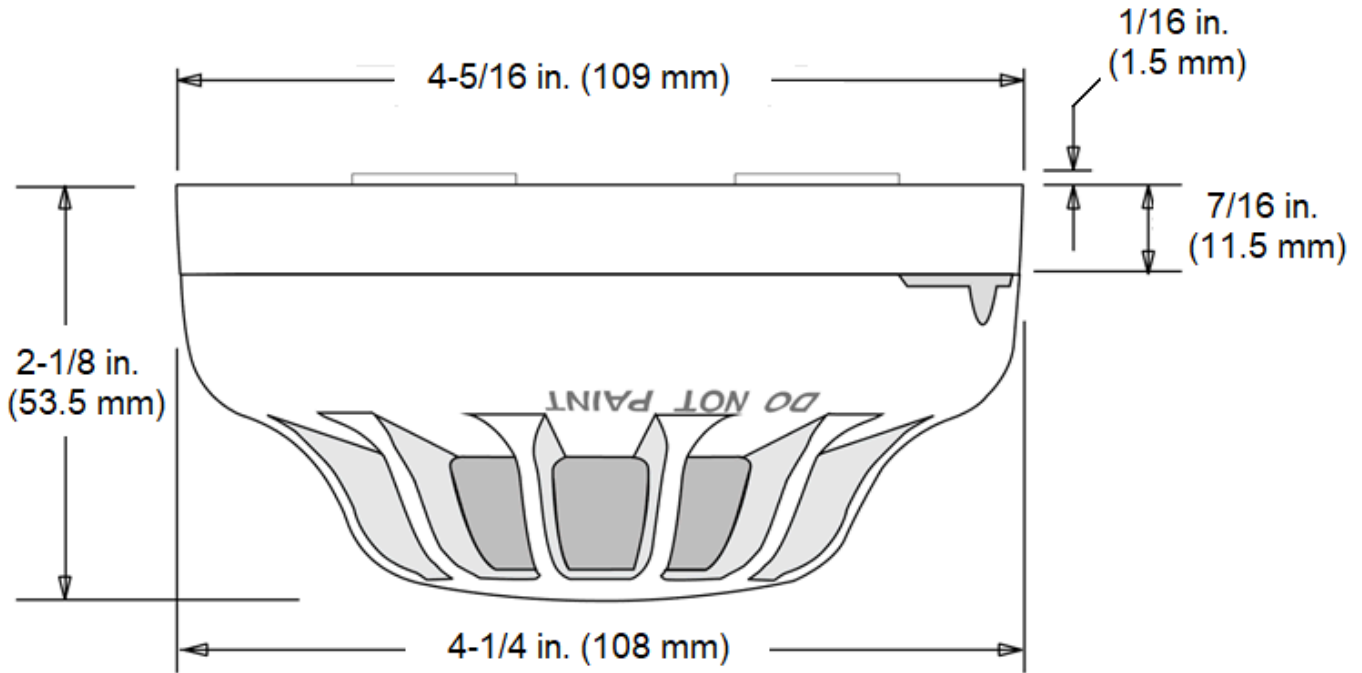
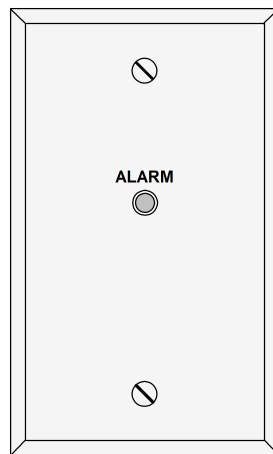

Figure 4: 2098-9808 Remote LED Indicator (not to scale)



Mounting information

Note: Electrical boxes are supplied by others.

Figure 5: Mounting Information

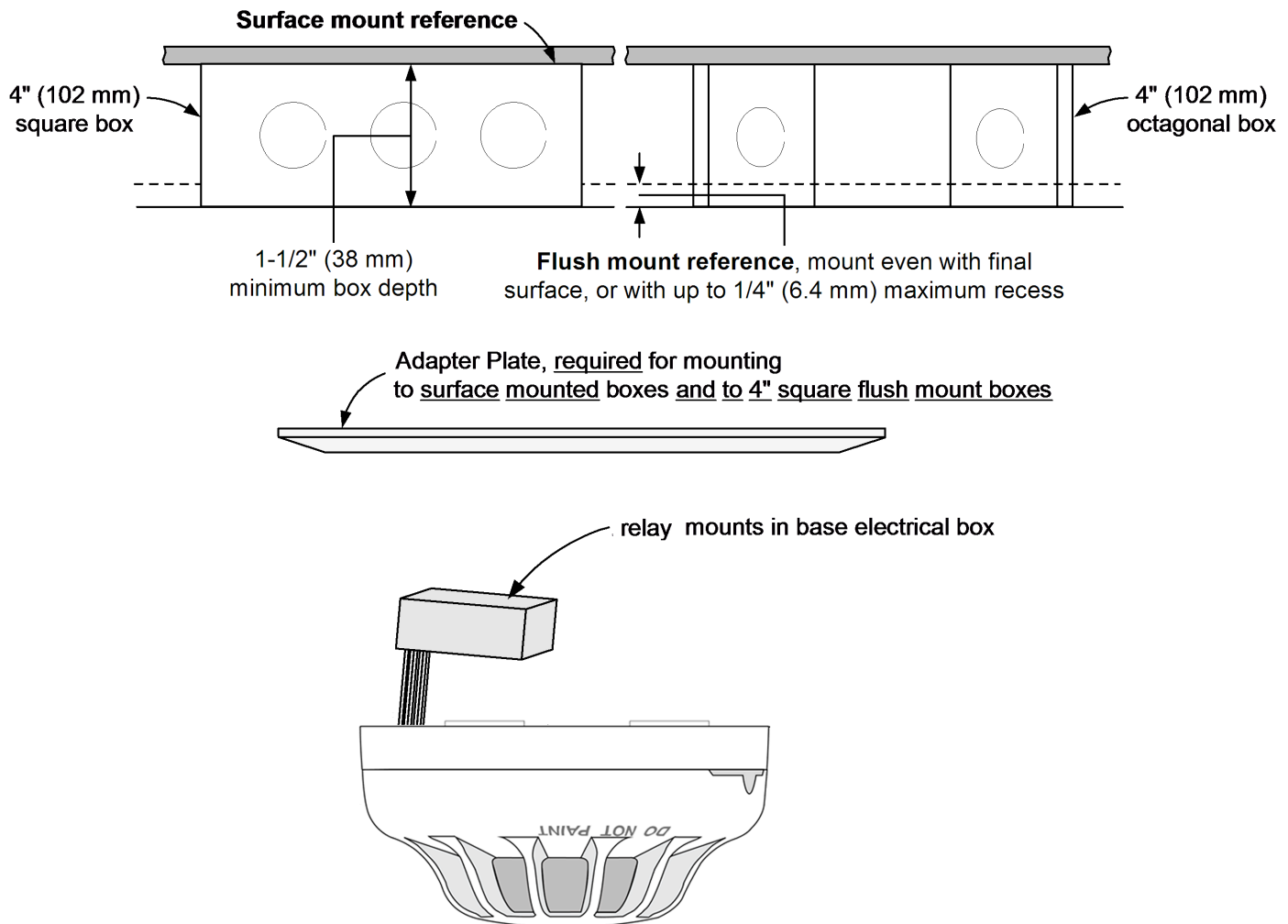

Note: Figure 5 shows:

- 4098-9799 adapter plate, required for mounting to surface mounted boxes and to 4 in. square flush mount boxes.
- A4098-5682 and A4098-5680 include a relay module that mounts in base electrical box.
- Smoke and heat detector bases, A4098-5207, A4098-5261, A4098-5682, A4098-5680.

Electrical box requirements

- Without relay (base A4098-5261): 4 in. octagonal or 4in. square, 1-1/2 in. deep Single gang, 2 in. deep
- With relay (bases A4098-5682 and A4098-5680): 4 in. octagonal, 1-1/2 in. deep, with 1-1/2 in extension ring 4 in. square, 1-1/2 in. deep, with 1-1/2 in extension ring